

DAW Power Technology Co., Ltd

5G communication base station Battery 48V Series Product Specification

Catalogue

I. Reference technical documents for battery system design.....	3
II. Use requirements for the battery system.....	3
III. Battery parameters.....	4
IV. Battery pack encoding rules.....	5
V. Identification.....	5
VI. 48V series battery pack size (50Ah / 100Ah / 150Ah / 200Ah, height is variable).....	6
VII. Battery pack structure.....	6
VIII. Specification and parameters of the protection board.....	7
IX. Operation and precautions.....	10
X. Product Reliability.....	10
XI. Storage and other matters.....	11
11.1. Long-term storage.....	11
11.2. Other matters.....	11
XII. Operation and precautions.....	11

I. Reference technical documents for battery system design

GB / T 191 Packaging, storage and transportation signs

GB / T 2408-2008 Plastics. Determination of burning properties. Horizontal method and vertical method

GB / T 2829-2002 Sampling procedures and tables for periodic inspection by attributes (applicable to inspection and inspection of process stability)

GB / T 17626.2-2018 Electromagnetic compatibility Test and measurement technology Electrostatic discharge immunity test

GB / T 17626.5-2019 Electromagnetic compatibility Test and measurement technology Surge (impact) immunity test

GB / T 20626.1-2006 Special Environmental Conditions Plateau Electrotechnical and Electronics Products-Part 1: General Technical Requirements

GB 50689-2011 Design code for lightning protection and grounding engineering of communication station

YD / T 983 communication power equipment electromagnetic compatibility limits and measurement method

YD / T 1051-2018 communication Bureau (station) power system general technical requirements

YD / T 1363.3-2014 Centralized Monitoring and Management System for Power Supply, Air Conditioning and Environment of Communication Bureau (Station) Part 3: Front-end Intelligent Equipment Protocol

YD / T 5040-2010 Code for installation of communication power equipment

YD / T 2344.1-2011 Lithium iron phosphate battery pack for communication Part 1: Integrated battery pack

YD / T 2344.2-2015 Lithium iron phosphate battery pack for communication Part 2: Discrete battery pack

II. Use requirements for the battery system

Battery system working external environment temperature requirements: charging: 0°C ~ 55°C, discharging working temperature range: -10°C ~ 55°C;

battery system working external environment humidity requirements: ≤95% (45°C±2°C);

battery system operation Try to maintain a SOC above 20% in the state;

When the battery system is not in use for a short period of time, it is required to maintain a SOC of more than 60% and store it in a dry, clean and well-ventilated warehouse at 5°C to 45°C;

During the process of battery packaging and loading, it is required to handle with care, prevent falling, rolling, and impact; Do not put the battery pack upside down or lying down in storage;

It is strictly forbidden to expose the battery pack to long-term exposure to the sun, rain, or water; ensure that the battery system is in operation or storage Keep away from flammable and explosive materials and high-temperature environments;

It is strictly forbidden to operate forcibly in the battery system short-circuit, overcharge, and high-temperature warning state; It is strictly forbidden for customers to disassemble the battery system without permission;

III . Battery parameters

Serial number	Project	Index	Remarks
48V series battery system parameters			
1	Rated voltage	48V	15 Strings
2	Battery pack voltage range	37.5 ~ 54.75V	According to single cell 2.5V-3.65V
3	Nominal capacity	50Ah 100Ah 150Ah 200Ah	At normal temperature, 0.1C discharge shall not be less than 99% of the base capacity; 1C discharge Not less than 90% of the base capacity
4	SOC scope	20%-100%	
5	Charge and discharge capacity efficiency	≥96%	
6	Maximum continuous charging current (A)	50 ~ 200	It can be configured upon customer request
7	Overcurrent protection (A)	50 ~ 200	It can be configured upon customer request
8	Cycle life	No less than 800 times	
9	Relative humidity of the environment	10%-90%	
10	Case material	SPCC	
11	Capacity preservation rate	≥96%	
12	Charge efficiency	≥97%	
13	Water dust protection standards	IP54	
14	Charge and discharge ambient temperature of the battery system	Discharge at between-10℃ and ~55℃	
		Charge for 0℃ ~55℃	
16	Environmental temperature of the storage and transportation of the battery system	Storage-40℃ ~70℃	

IV. Battery pack coding rules

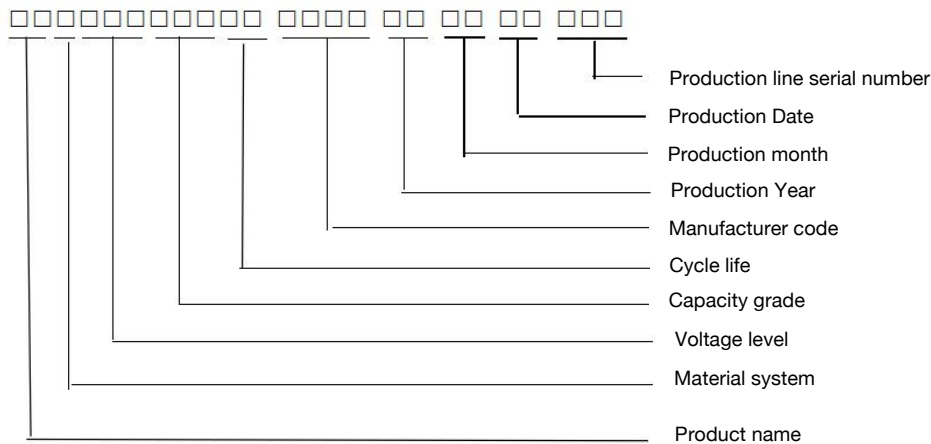

- Product name: BD for backup power lithium battery pack;
- Voltage level: 48V series for 48;
- Capacity level: 100Ah for specification 100;
- Material system: Lithium iron phosphate code 1;
- Cycle life: 800 cycles are marked with 08, 1500 cycles are marked with 15;
- Manufacturer code: Lithium battery manufacturer's English code, if the manufacturer's English code is less than four digits, the front will be filled with a number "0", which will be uniformly divided by the tower company match;
- Production year: Take the last two digits according to the actual production year; for example, for the battery produced in 2019, the year code is 19; Production month: use the number "01-12" to indicate;
- Production date: expressed by the number "01 ~ 31";
- Production line serial number: According to the Nth group of this type of product produced on the day of production by the manufacturer, the number is N (for example, for the first group of a certain model, N is 001).

V. Identification

The product name, product model, rated voltage \ capacity, factory time, production line serial number, manufacturer number and other relevant information shall be marked in text and QR code on the mechanical and electrical unit shell of the battery pack. The battery pack identification format is shown in Table 2, where the execution standard number, factory site, zip code and contact telephone identification are allowed to be printed in the package or instruction manual.

Each set of products shall record the qualified factory battery pack code, and the code, internal resistance, voltage, capacity and other information of each cell in the battery pack.

Example of the battery identification format

Sort	Identify content	Identity example	Remarks
First line	Product name	xxxx cell	Battery labels and QR code labels should be included
The second line	Product model	xxxx	
The third line	Rated voltage \ capacity	xxV\xxAh	
The fourth line	Factory time	xxxx year	
The fifth line	Line serial number	xxxx	
Line 6	Manufacturer's name	xxxx	
Line 7	Battery pack coding	XXXXXXXXXX	

VI. 48V series battery pack size (50Ah / 100Ah / 150Ah / 200Ah, height is variable)

Serial number	Capacity specification	Width	Maximum altitude	Depth capacity
1	50Ah (cylindrical cell)	442mm (Including 482mm of hanging ear)	133mm (3U)	480mm
2	100Ah, (Square cell)		222mm (5U)	
3	150Ah, (Square cell)		265 (6U)	
4	200Ah, (Square cell)		265 (6U)	

1U=44.45mm

VII. Battery pack structure

Schematic appearance of the battery pack



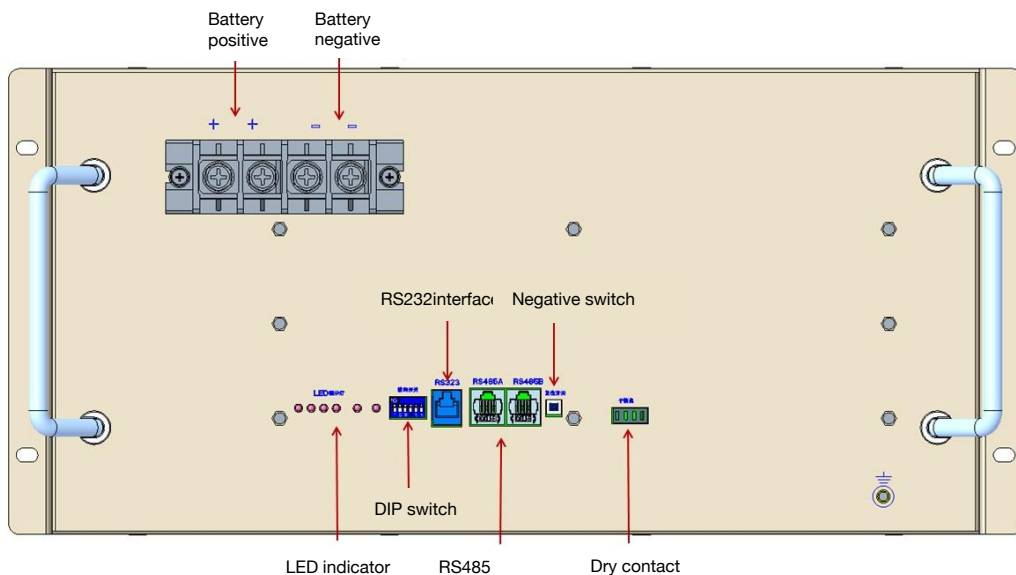

Schematic diagram of the battery pack panel

VIII. Specification and parameters of the protection board

1. Protection plate model: lithium iron 15 string 50~200A (configured according to customer requirements)
2. Electrical parameters (room temperature 25°C humidity 55% at room temperature)

Function name	Functions are	List of projects	Default value	Set the instructions	set up
Single voltage alarm	open	Overvoltage alarm voltage	3600mV		
	open	Under voltage alarm voltage	2500mV		
Single unit overvoltage protection	open	Overvoltage protection voltage	3750		
		Overvoltage protection delay	1S		
		Overvoltage protection recovery voltage	3600mV		
Single owed pressure protection	open	Overpressure protection voltage	2000mV		
		Time-lapse of pressure protection	1S		
		Undervoltage protection recovery voltage	2900mV		
Overall voltage alarm	open	Overpressure alarm voltage	53.5V		
	open	Overpressure alarm voltage	40.5 V		
Overall		Overpressure protection voltage	54V		

		Overpressure protection delay	1S		
		Overvoltage protection recovery voltage	52.1V		
Battery under pressure protection	open	Overpressure protection voltage	40.5V		
		Time-lapse of pressure protection	1S		
		Undervoltage protection recovery voltage	48V		
Core temperature protection	open	Charge high temperature protection	50°C		
		Charging low temperature alarm	5°C		
		Discharge high temperature protection	50°C		
		Discharge low temperature alarm	0°C		
The temperature of the cell shall not be charged	open	Charge high temperature protection	65°C		
		Charging high temperature recovery	50°C		
		Charging low temperature protection	0°C		
		Charging low temperature recovery	5°C		
The temperature of the cell is banned	open	Discharge high temperature protection	65°C		
		Restore the high temperature of discharge	50°C		
		Low temperature protection of discharge	-10°C		
		Restore the discharge at low temperature	0°C		
Environmental temperature alarm	open	Environmental high temperature alarm	50°C		
		Environmental low temperature alarm	0°C		
MOS high-temperature alarm	open	MOS high-temperature alarm	100°C		
Charge the police over the stream	open	Charging alarm current	100A		

Charge over-flow protection	open	Charging protection current	105A		
		Charge over-flow delay	4S		
Discharge and report to the	open	Discharge the police and pass the flow	95A		
Discharge over-current protection	open	Discharge to protect current	105A		
		Time-lapse of discharge over-flow	5S		
Secondary discharge overcurrent protection	open	Secondary protection current	150A		
		Secondary overflow delay	500mS		
Output short circuit protection	open	Short circuit protection current	330A		
		Short circuit protection delay	500uS		
		Short circuit protection is lifted	Charging is discharged, and the charging current is 2A		
Overdischarge is automatically restored	Automatic recovery delay		15mins	Automatic recovery for about 15 minutes	
Cell equilibrium function	open	The cell charging is balanced	Opening condition: the shape of the effective charging current		
		Equally open the voltage	3500mV		
		Equally open the pressure difference	20mV		
Battery capacity setting	Battery rated capacity		200Ah		
	open	Low power alarm	SOC alarm 1 is: 30% (not available) alarm 2 is: 15% (not available)		
Manual button setting	Starting up	BMS is dormant, key 1S is turned on			
	Shut down	The BMS is in the non-charge state, with the key 3S to turn on			
BMS power consumption management	Sleep time	1440Mins (no communication, no charge and discharge current)			

IX. Operation and precautions

No	Project	Test method and determination criteria
1	Charging performance	Use the original charger, and you can charge it. Standard charging mode: At $23 \pm 2^{\circ}\text{C}$, the battery is charged at 0.1C when the battery voltage reaches 54V to constant voltage until stopped when the charging current is less than or equal to 0.02C.
2	Discharge performance	The battery has an external load and can supply power. After the battery is charged in the charging mode, hold the open circuit for 0.5h, and then discharge to 41.25V at 0.1C. The discharge time is 10h; the cycle can be repeated 5 times. When the capacity of one cycle
3	Cycle life	The battery is charged at $23 \pm 2^{\circ}\text{C}$ at 0.1C. When the voltage reaches 57.6V, the constant voltage is changed until the charging current is less than or equal to 0.02C is stopped. After resting for 0.5h, 0.1C discharges to 44.0V. When the continuous cycle discharge time is <8H (80%), the cycle life is required 1000 times.
4	Charge-holding capacity	The battery is charged at 0.1C, when the end voltage reaches 54V to constant voltage, the charging current is less than or equal to 0.02C, put the battery open at $23 \pm 2^{\circ}\text{C}$ after 28 days, discharged to 41.25.0V at 0.1C, required discharge time of 8.5h.
5	Storage performance	After charging 0.1C with 40 to 50% capacity, placing the battery in an open circuit for 12 months after $20 \pm$ at a temperature of 5°C humidity of 45 to 75% for 12 months, charge $23 \pm$ to 54V at 0.1C at 2°C . Charge for 0.5h, and 41.25V at 0.1C. The discharge time is required for 8h. The cycle can be repeated 5 times, and the test can stop when the cycle capacity meets the requirements.

X. Product Reliability

No	project	Test method and determination criteria
1	Elevated temperature property	At $23 \pm 2^{\circ}\text{C}$, after the battery is charged at 0.1C, the battery is placed in a $55 \pm 2^{\circ}\text{C}$ constant temperature and humidity tank at constant temperature for 2h, and then discharged to 41.25V at 0.1C current, requiring the discharge time of 10H, and the battery appearance is not deformed and smoking.
2	Cryogenic property	At $23 \pm 2^{\circ}\text{C}$, after the battery is charged at 0.1C, then the battery is placed in a constant temperature and humidity tank of $-10 \pm 2^{\circ}\text{C}$ at constant temperature for 4h, and then discharged to 41.25V at 0.1C current. The required discharge time is 6h, and the battery appearance is not deformed and smoking.

3	Overcharging protection performance	After the battery is fully charged at 0.1C, the constant current constant pressure source is set to 2 times the nominal voltage current, and then loaded on the battery for 7h, requiring that the battery will not have leakage, deformation, smoke and explosion during the test.
4	Overdischarge protection performance	At $23 \pm 2^{\circ}\text{C}$, after the battery is discharged at 0.1C to 44.0V, external $n \times 30 \Omega$ (n means strings) load for another 7h, requiring the battery does not leak liquid, fire, smoke and explosion during the experiment.
5	Short-circuit protection performance	At $23 \pm 2^{\circ}\text{C}$, after the battery is fully charged at 0.1C, the battery short positive and negative electrode (external resistance less than $80 \pm 20\text{m} \Omega$) for 1h, the battery without leakage, deformation, smoke and explosion during the test.
6	Constant hot and humid performance	At $23 \pm 2^{\circ}\text{C}$, after the battery is charged at 0.1C, put into $40 \pm 2^{\circ}\text{C}$, a constant temperature and humidity tank with 90~95% humidity for 48h, the battery should have no obvious deformation, leakage, rust, smoke or explosion, removed the battery for 2h and discharged to 41.25V at $23 \pm 2^{\circ}\text{C}$, the discharge time is 6H.

XI. Storage and other matters

12.1. Long-term storage

Long-term stored batteries (more than 3 months) must be placed in dry, cool places. Storage voltage is 48~51.5V. It was stored at $23 \pm 2^{\circ}\text{C}$ with levels of 45% -75% humidity clean environment.

12.2. Other matters

Not mentioned in this specification shall be determined through negotiation by both parties.

XII. Operation and precautions

Caution!

- Do not put the battery or wet it!
- No charging of batteries under fire sources or extremely hot conditions! Do not use or store batteries near a heat source (such as a fire or heater)! If the battery leaks or smells bad, remove it immediately from near an open fire;
- Use a dedicated charger!
- Do not connect the positive and negative poles back!
- Do not connect the battery directly to the wall socket or the car cigarette lighting type socket!
- Do not put the battery on fire or heat it!
- It is forbidden to short-circuit positive or negative batteries with wires or other metal objects, or to transport or store batteries together with necklaces, hairpins, or other metal objects!
- Do not puncture the battery housing with nails or other sharp objects, do not hammer or pedal the battery!
- No impact, throwing, or mechanical vibration of the battery
- Direct welding of the battery terminals is prohibited!
- Never decompose the battery in any way!
- No battery placement in a microwave oven or pressure vessel!

- No combination with primary battery (such as dry battery) or different capacities, models and varieties!
- The battery shall not be used with odor, heat, deformation, discoloration, or any other abnormality; if the battery is in use or charging, it shall be immediately removed from the appliance or from the charger!

Caution!

Do not use batteries in an extremely hot environment, such as direct sunlight or in hot days. Otherwise, the battery may catch fire (ignite), seriously affecting the performance of the battery, shorten the service life of the battery and the safety of the user.

If the electrolyte enters the eyes after the battery leaks, do not wipe it, rinse with water, and seek medical assistance immediately. If not treated in time, the eyes will be injured.